

INSTALLATIONSANLEITUNG FENSTERABDICHTUNG

Installation instructions window seal

AirLock 100



AirLock 200



Installationsanleitung AirLock 100 / AirLock 200



1 Fenster zuerst öffnen und die zu beklebenden Flächen auf dem Fenster- rahmen und -flügel reinigen, so dass sie frei von Staub und Fett sind. Klett- verschluss öffnen und das Klettband (**Seite A**) auf den Fensterrahmen kleben.

Nicht auf die Anlagefläche der Fensterabdichtung kleben (Fenster muss sich weiterhin schließen lassen)!



6 Fenster einen Spalt weit öffnen und den Luftschlauch mit Hilfe des Reißverschlusses im AirLock 100 / 200 einklemmen.



2 Klettband (**Seite B**) auf die **a**) Außen- oder **b**) Innenseite des Fensterflügels kleben (Fenstergriffseite).

Achten Sie darauf, dass sich das Fenster weiterhin schließen lässt. Prüfen Sie vor dem Verkleben, dass der Klebestreifen nicht die Fensterrahmen beschädigt!



7 Der AirLock 100 / 200 ist jetzt einsatz- bereit.



3 Erst die breite **Seite A** (Reißverschluss bleibt geschlossen) bei geöffnetem Fenster von der Mitte weg nach links und rechts, bzw. nach oben und unten komplett am Fensterrahmen ankletten.

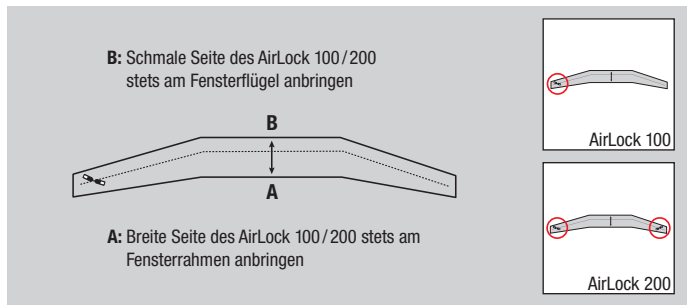

4 Fenster schließen und darauf achten, dass der AirLock 100 / 200 dabei nicht eingeklemmt wird.

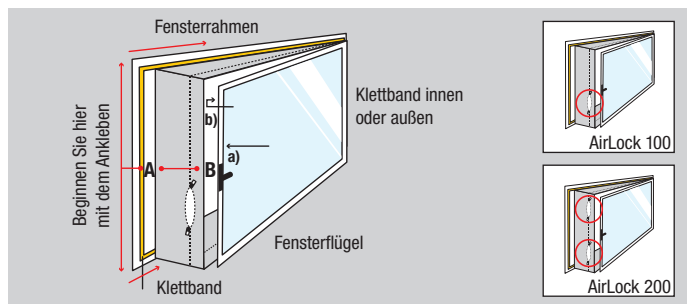

5 Die schmale **Seite B** (bei geschlossenem Reißverschluss) von der Mitte weg nach links und rechts bzw. nach oben und unten komplett am Fensterflügel ankletten.

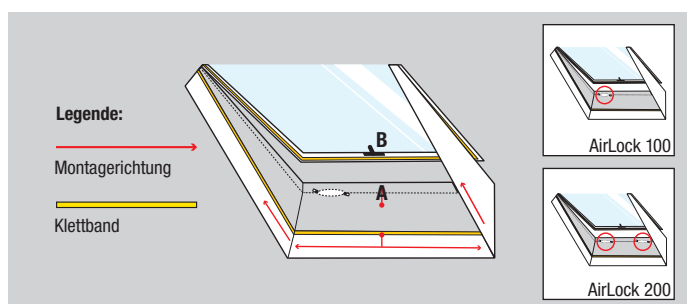

Installation instructions AirLock 100 / AirLock 200



First open the window and clean the surfaces to be bonded from dust and fat on the window frame and casement. Open the Velcro fastener and stick the Velcro strap to the window frame (**side A**).

Never stick it to the contact surface of the window seal (window must still be able to close)!



Stick Velcro strap (**side B**) to the **a)** outside or **b)** inside of the window casement (side of the window handle).

Be sure that the window still is able to close. Before sticking together make sure that the sticky tape doesn't damage the window frames!



First stick the wide **side A** (zipper is closed) with open windows from the middle to the left and right side or to the up and down side to the window frame.

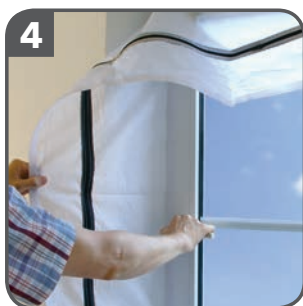

Close window and make sure that the AirLock 100/200 isn't clamped.



Stick the narrow **side B** (zipper is closed) from the middle to the left and right side or to the up and down side to the casement.



Open window slightly and pinch air hose in the AirLock 100/200 by using the zipper.



The AirLock 100/200 is ready for use now.

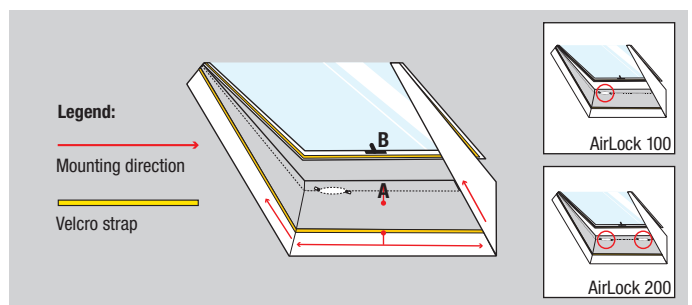
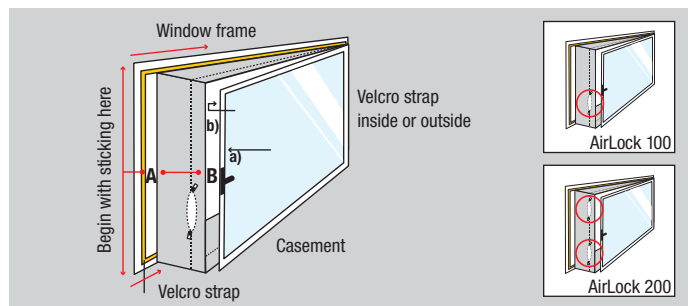
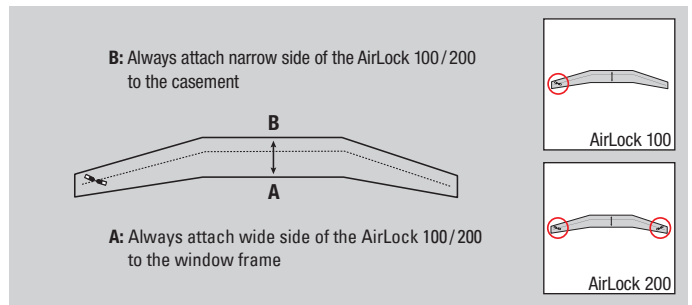

Notice d'installation AirLock 100 / AirLock 200



1 Ouvrir la fenêtre. Nettoyer la surface de l'encadrement et du battant de fenêtre pour enlever la poussière et d'éventuels dépôts gras. Coller les bandes auto-agrippantes (**côté A**) sur l'encadrement.

Ne pas fixer sur l'intérieur, directement à côté du joint de fenêtre (la fenêtre doit pouvoir se fermer)!



6 Ouvrir légèrement la fenêtre et faire passer la gaine d'évacuation du climatiseur dans une ouverture laissée par la fermeture éclair du kit AirLock 100/200.



2 Coller les bandes auto-agrippantes (**côté B**) au choix sur le côté **a)** extérieur ou **b)** intérieur de la fenêtre (côté poignée). Veiller à ce que la fenêtre puisse se fermer.

Vérifier avant de coller définitivement que la surface collante n'endommage pas l'encadrement de fenêtre



7 Le calfeutrage de fenêtre AirLock 100/200 est installé.



3 Laisser la fenêtre ouverte. D'abord, fixer le **côté A** le plus large du voile (fermeture éclair fermée) sur l'encadrement en partant du centre vers les côtés droit et gauche et vers le haut et le bas.

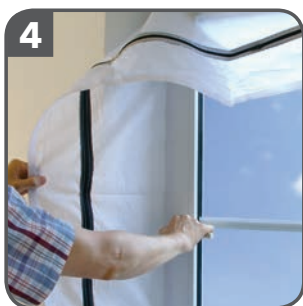
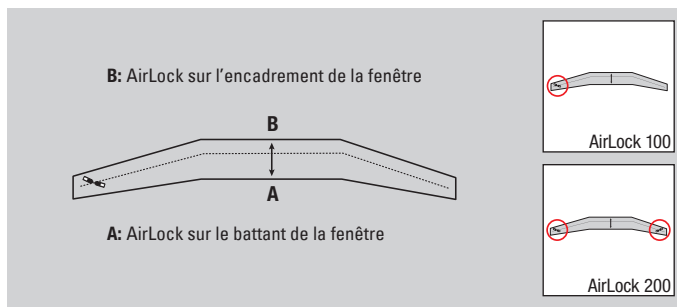

4 Fermer la fenêtre en veillant à ne pas coincer le voile.

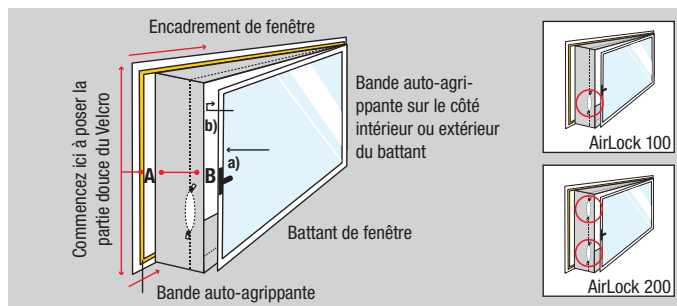

5 Fixer le côté le plus étroit **B** (fermeture éclair fermée) sur le battant de fenêtre en partant du centre vers les côtés droit et gauche et vers le haut et le bas.

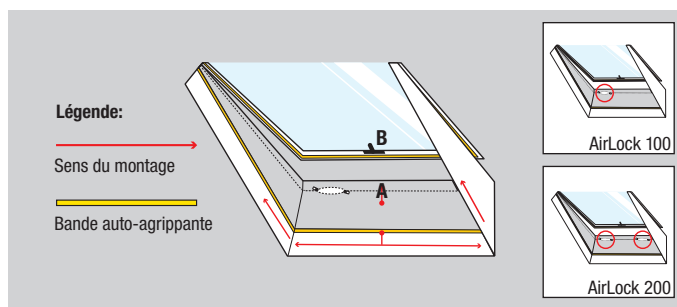

Istruzioni d'uso AirLock 100 / AirLock 200



1 Aprire la finestra e pulire per bene l'anta e il telaio della finestra dove applicare la guarnizione, eliminando polvere e grasso. Aprire la chiusura a strappo e far aderire il nastro adesivo (**lato A**) al telaio della finestra. **Non attaccare lo strappo sulla superficie di contatto tra telaio e anta (la finestra si deve poter chiudere normalmente anche se la guarnizione è montata)!**



6 Aprire la finestra quanto basta e far uscire il tubo di scarico tramite la cerniera dell'AirLock 100/200.



2 Attaccare il nastro adesivo (**lato B**) sul lato **a)** esterno o **b)** interno dell'anta della finestra (lato con la maniglia).

Attenzione: la finestra deve poter chiudersi dopo aver terminato questo passaggio. Prima di attaccare il nastro adesivo, controllare che le strisce adesive non rovinano il bordo della finestra!



7 L'AirLock 100/200 è adesso installato correttamente.



3 Tenendo la finestra aperta, attaccare per primo il **lato largo A** al telaio della finestra partendo dal centro verso sinistra, destra, l'alto e il basso (la cerniera rimane chiusa).

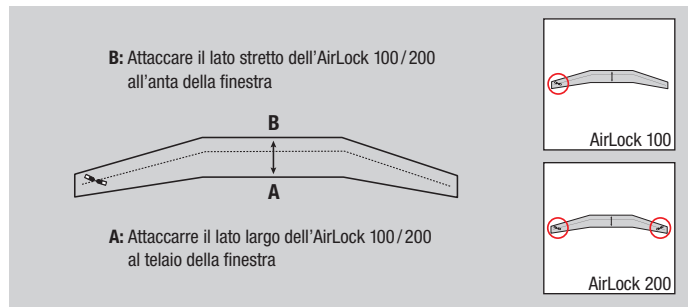

4 Chiudere la finestra e controllare che AirLock 100/200 non vi ci rimanga incastrato.

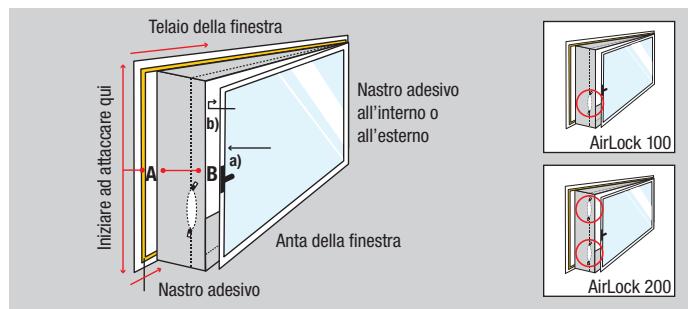

5 Attaccare il **lato stretto B** (con cerniera chiusa) all'anta della finestra partendo dal centro verso sinistra, destra, l'alto e il basso.

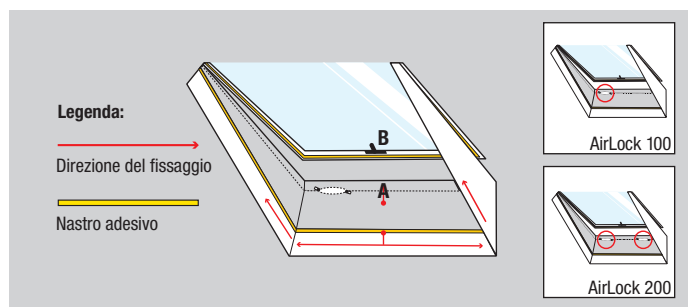

Installatie instructie AirLock 100 / AirLock 200



Raam eerst openen en de oppervlakte op het raamkozijn en vleugel reinigen waarop moet worden geplakt, zodat deze stof- en vetvrij zijn. Klitteband openen en klitteband (**Kant A**) op het raamkozijn plakken.

Niet op de oppervlakte plakken waar de vleugel tegen het kozijn komt bij een gesloten raam, het raam moet nog dicht kunnen!



Raam op een kier openen en de luchtslang met behulp van de ritssluiting aan de airlock 100/200 in het gat klemmen. De ritssluiting zover openen of sluiten totdat de slang vastzit.



Klittenband (**Kant B**) op de:
1) Binnenkant (a) van de vleugel (aan de kant van de handgreep/in de kamerrichting) plakken **of**.

2) Buitenkant (b) van de vleugel (richting buiten) plakken.

Let u erop dat zich het raam nog steeds laat sluiten. Controleer voor het plakken dat de plakstrip het raam niet beschadigt!



De Airlock 100/200 is nu gebruiksklaar.



Eerst de brede **kant A** (de rits blijft gesloten) bij geopend raam vanaf het midden naar links en rechts oftewel naar boven en beneden compleet aan het kozijn plakken.

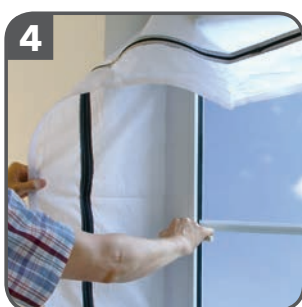
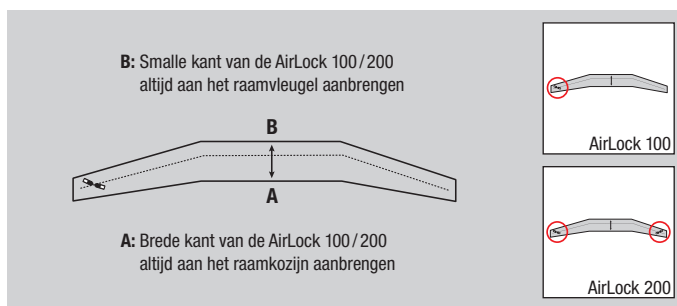

Raam sluiten en hierbij erop letten dat de Airlock 100/200 niet ertussen geklemd wordt.

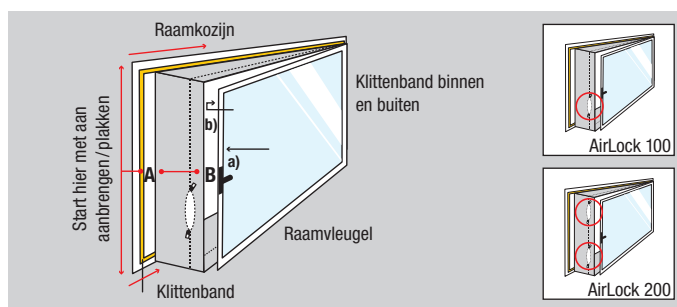

De smalle **kant B** (bij gesloten ritssluiting) vanaf het midden naar links en rechts oftewel van boven en beneden compleet aan de raamvleugel plakken.

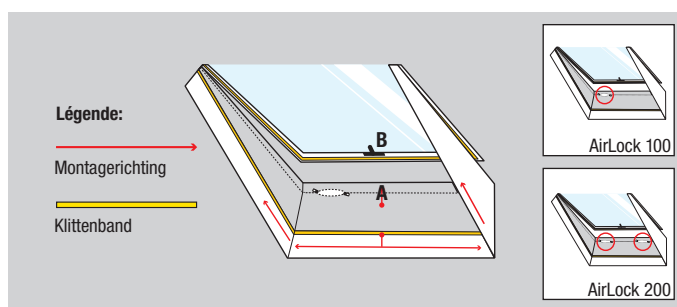

Instrukcja instalacji Airlock 100 / Airlock 200



1 Otwórz okno a następnie oczyść z kurzu i tłuszczu powierzchnie ramy i skrzydła okiennego, które mają być oklejone. Otwórz zabezpieczenie rzepa i przyklej taśmę z rzepem (**strona A**) na ramie okiennej.

Nie zaklejaj powierzchni uszczelnienia okna (okno musi dawać się zamykać)!



6 Uchyl okno i przy pomocy zamka błyskawicznego zaciśnij przewód powietrza w AirLock 100 / 200.



2 Taśmę z rzepem (**strona B**) przyklej po **a)** stronie zewnętrznej lub **b)** stronie wewnętrznej skrzydła okiennego (stronie z uchwytem okiennym).

Uważaj aby okno można było zamykać. Sprawdź przed naklejeniem czy taśma klejąca nie uszkodzi ramy okiennej!



7 AirLock jest teraz przygotowany do korzystania z niego.



3 Najpierw w otwartym oknie przymocuj szeroką **stronę A** (zamek błyskawiczny pozostaje zapięty) na ramie okiennej poczynając od środka i kontynuując w prawo i lewo, względnie w górę i w dół.

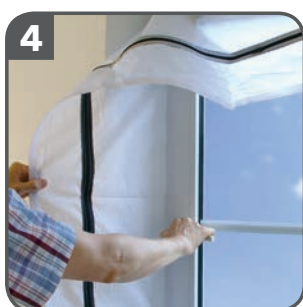
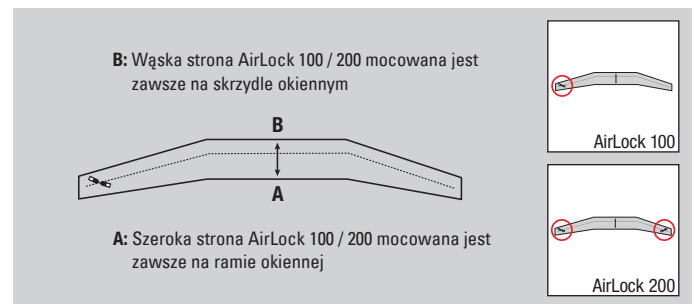

4 Zamknij okno uważając aby nie przycisnąć przy tym AirLock 100 / 200.

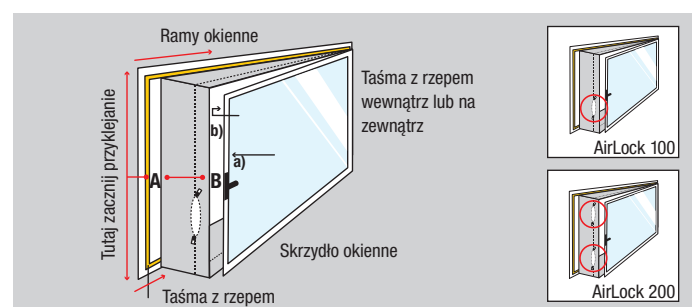

5 Wąską **stronę B** (z zamkniętym zamkiem błyskawicznym) przymocuj do skrzydła okiennego poczynając od środka kontynuując w prawo i lewo, względnie w górę i w dół.

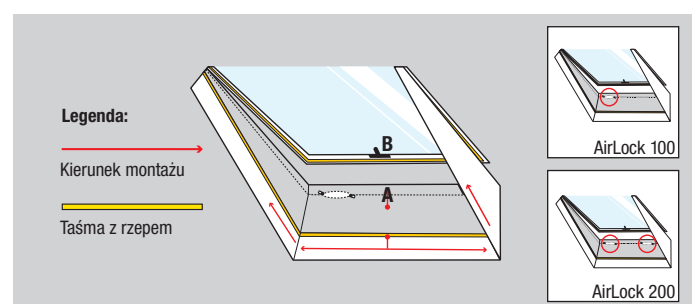

Trotec GmbH

Grebener Straße 7
52525 Heinsberg
Germany

📞 +49 2452 962-0

📠 +49 2452 962-200

✉ online@trotec.com

www.trotec.com