

TTP 1 E / TTP 2 E

EN

INSTRUCTIONS
DEHUMIDIFIER



Table of contents

Information on the use of these instructions 2

Safety 2

Information about the device..... 4

Transport and storage..... 5

Assembly and start-up 6

Operation 7

Errors and faults 8

Maintenance 9

Technical annex..... 11

Disposal 12

You can download the current version of the instructions and the EU declaration of conformity via the following link:



TTP 1 E



<https://hub.trotec.com/?id=41306>

TTP 2 E



<https://hub.trotec.com/?id=41307>

Information on the use of these instructions

Symbols



Warning of electrical voltage

This symbol indicates dangers to the life and health of persons due to electrical voltage.



Warning

This signal word indicates a hazard with an average risk level which, if not avoided, can result in serious injury or death.



Caution

This signal word indicates a hazard with a low risk level which, if not avoided, can result in minor or moderate injury.

Notice

This signal word indicates important information (e.g. material damage), but does not indicate hazards.



Info

Information marked with this symbol helps you to carry out your tasks quickly and safely.



Follow the manual

Information marked with this symbol indicates that the instructions must be observed.

Safety

Read this manual carefully before starting or using the device. Always store the manual in the immediate vicinity of the device or its site of use.



Warning

Read all safety warnings and all instructions.

Failure to follow the warnings and instructions may result in electric shock, fire and/or serious injury.

Save all warnings and instructions for future reference.

This appliance can be used by children aged from 8 years and above and persons with reduced physical, sensory or mental capabilities or lack of experience and knowledge if they have been given supervision or instruction concerning use of the appliance in a safe way and understand the hazards involved.

Children shall not play with the appliance. Cleaning and user maintenance shall not be done by children without supervision.

- Do not use the device in potentially explosive rooms or areas and do not install it there.
- Do not use the device in an aggressive atmosphere.
- Place the device in an upright and stable position on horizontal and stable ground.
- Let the device dry out after a wet clean. Do not operate it when wet.
- Do not use the device with wet or damp hands.

- Do not expose the device to directly squirting water.
- Do not cover the device during operation.
- Do not sit on the device.
- This appliance is not a toy. Keep away from children and animals.
- Occasionally observe the device during operation.
- Check accessories and connection parts for possible damage prior to every use of the device. Do not use any defective devices or device parts.
- Ensure that all electric cables outside of the device are protected from damage (e.g. caused by animals). Never use the device if electric cables or the power connection are damaged!
- Check the power cable and mains plug for damage. If you notice damages, do not try to take the device back into operation. Order a new power cable with mains plug from the manufacturer and replace the defective power cable with mains plug with the new one.
Defective power cables pose a serious health risk!
- The mains connection must correspond to the specifications in the Technical annex.
- Insert the mains plug into a properly fused mains socket.
- Observe the device's power input, cable length and intended use when selecting extensions to the power cable. Completely unroll extension cables. Avoid electrical overload.
- Before carrying out maintenance, care or repair work on the device, remove the mains plug from the mains socket. Hold onto the mains plug while doing so.
- Switch the device off and disconnect the power cable from the mains socket when the device is not in use.
- When positioning the device, observe the minimum distances from walls and other objects as well as the storage and operating conditions specified in the Technical annex.
- Make sure that the air inlet and outlet are not obstructed.
- Make sure that the suction side is kept free of dirt and loose objects.
- Never insert any objects or limbs into the device.
- Do not remove any safety signs, stickers or labels from the device. Keep all safety signs, stickers and labels in legible condition.
- Only transport the device in an upright position with an emptied condensation tank or drain hose.
- Discharge the collected condensate before transport and storage. Do not drink it. Health hazard!
- Only use original spare parts, for otherwise safe and functional operation cannot be ensured.

Intended use

Only use the device for keeping the room air in spatially limited areas dry whilst adhering to the technical data.

Intended use includes keeping the following dry:

- small living spaces
- closets and shoe cabinets
- bookshelves
- pantries and storerooms
- bathrooms
- small, windowless sanitary facilities etc.

Any use other than the intended use is regarded as misuse.

Reasonably foreseeable misuse

- The device is not intended for industrial use.
- Do not place any objects, e.g. clothing, on the device.
- Do not use the device out of doors.
- Do not use the device in the immediate vicinity of swimming pools, bathtubs and showers.
- Never immerse the device in water.
- Do not make any unauthorised modifications, alterations or structural changes to the device.
- Do not place the device on wet or flooded ground, e.g. near floor drains.

Personnel qualification

People who use this device must:

- be aware of the dangers that occur when working with electric devices in damp areas.
- have read and understood the instructions, especially the Safety chapter.

Maintenance tasks which require the housing to be opened must only be carried out by specialist electrical companies or by the manufacturer.

Residual risks



Warning of electrical voltage

Work on the electrical components must only be carried out by an authorised specialist company!



Warning of electrical voltage

Risk of electric shock!

The device is not protected against water.

There is a risk of electric shock!

Never use the device in areas where dripping, spraying or running water can enter the device! Never immerse the device in water!



Warning of electrical voltage

Risk of electric shock!

Risk of an electric shock if the device comes into contact with water!

Do not use this device in the immediate vicinity of bathtubs, showers or swimming pools!



Warning of electrical voltage

Before any work on the device, remove the mains plug from the mains socket!

Do not touch the mains plug with wet or damp hands.

Hold onto the mains plug while pulling the power cable out of the mains socket.



Warning

Dangers can occur at the device when it is used by untrained people in an unprofessional or improper way! Observe the personnel qualifications!



Warning

The device is not a toy and does not belong in the hands of children.



Warning

Risk of suffocation!

Do not leave the packaging lying around. Children may use it as a dangerous toy.

Behaviour in the event of an emergency

1. Switch the device off.
2. Disconnect the device from the mains: Hold onto the mains plug while pulling the power cable out of the mains socket.
3. Do not reconnect a defective device to the mains.

Information about the device

Device description

The device uses the principle of condensation and a Peltier element to dehumidify small rooms in a silent manner.

The fan sucks in damp room air through the air inlet. The room air is cooled at the cold side of the Peltier element until it is below the dew point. Water vapour contained in the room air precipitates as condensation or rime. The dehumidified, cooled air is blown out. The drier air thus conditioned mixes with the air in the room. The humidity in the room where the device is positioned is reduced as air constantly circulates through the device.

Depending on the air temperature and the relative humidity, the condensed water drops into the condensation tank. The latter is fitted with a float to measure the filling level.

If the maximum level of the condensation tank is reached or if the float is not correctly positioned, the indicator LED lights up red. The device switches off. The indicator LED only goes out again once the emptied condensation tank is reinserted.

The functioning of the two devices is identical, they merely differ in appearance or to be precise in colour: The device TTP 1 E is brown and the device TTP 2 E is white.

The device is not protected against water (IPX0).

Device depiction

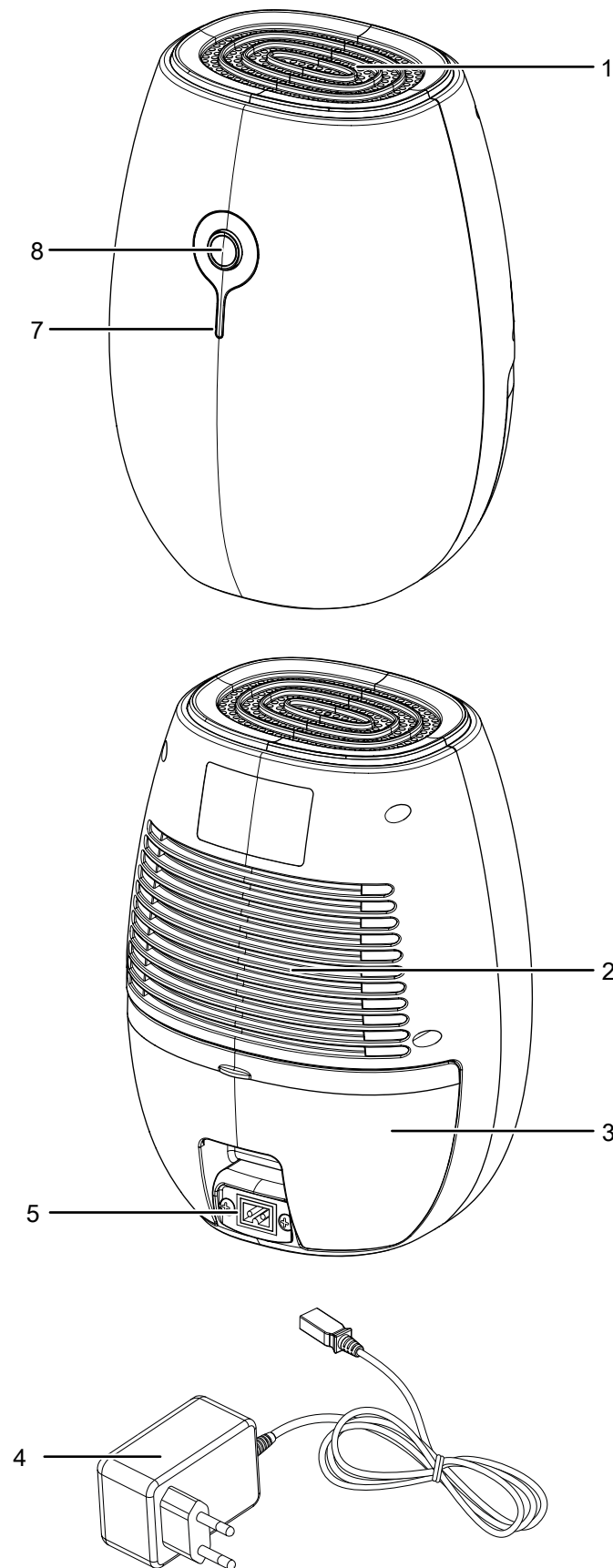

No.	Designation
1	Air outlet
2	Air inlet
3	Condensation tank
4	Power adapter
5	Power adapter connection
7	Indicator LED: <ul style="list-style-type: none"> • is illuminated blue when the device is switched on and during operation • flashes blue if the power adapter is defective • is illuminated red when the water tank is full or the float is incorrectly positioned
8	On/off switch

Transport and storage

Notice

If you store or transport the device improperly, the device may be damaged.

Note the information regarding transport and storage of the device.

Transport

Before transporting the device, observe the following:

- Switch the device off.
- Hold onto the mains plug while pulling the power cable out of the mains socket.
- Drain the remaining condensate from the device.
- Do not use the power cable to drag the device.

After transporting the device, proceed as follows:

- Set up the device in an upright position after transport.

Storage

Before storing the device, proceed as follows:

- Drain the remaining condensate from the device.
- Hold onto the mains plug while pulling the power cable out of the mains socket.

When the device is not being used, observe the following storage conditions:

- Store the device in a dry location and protected from frost and heat.
- Store the appliance in an upright position where it is protected from dust and direct sunlight.
- If required, use a cover to protect the device from invasive dust.
- Place no further devices or objects on top of the device to prevent it from being damaged.

Assembly and start-up

Scope of delivery

- 1 x Device
- 1 x Power adapter
- 1 x Manual

Unpacking the device

1. Open the cardboard box and take the device out.
2. Completely remove the packaging.
3. Fully unwind the power cable. Make sure that the power cable is not damaged and that you do not damage it during unwinding.

Start-up

When positioning the device, observe the minimum distance from walls or other objects as described in the chapter Technical annex.

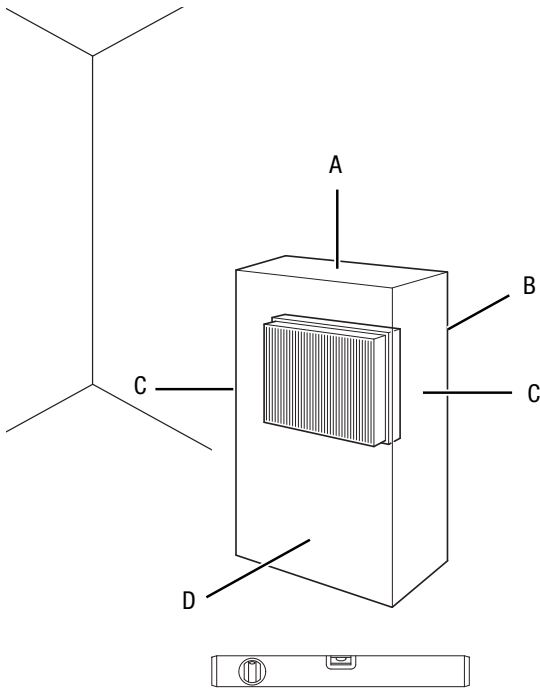

- Before restarting the device, check the condition of the power cable. If there are doubts as to the sound condition, contact the customer service.
- Place the device in an upright and stable position on horizontal and stable ground.
- Do not create tripping hazards when laying the power cable or other electric cables, especially when positioning the device in the middle of the room. Use cable bridges.
- Make sure that extension cables are completely unrolled.
- When positioning the device, keep a sufficient distance to heat sources.
- Make sure that no curtains or other objects interfere with the air flow.

Inserting the condensation tank

- Ensure that the float (6) inside the condensation tank is inserted correctly.

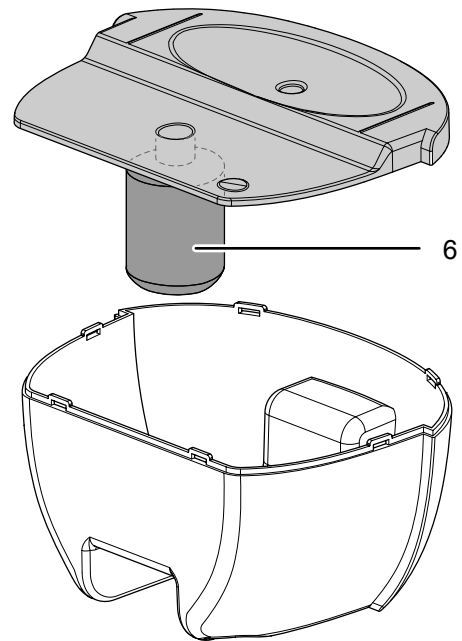

- Ensure that the condensation tank (3) is empty and inserted correctly.

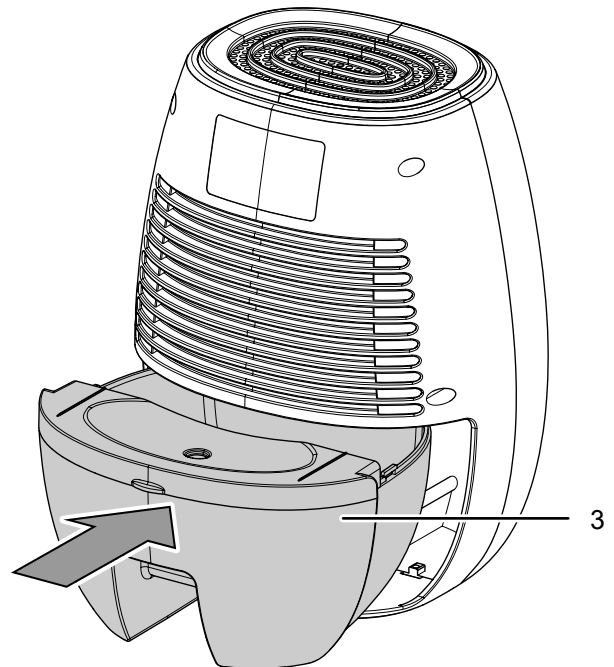

Connecting the power adapter

- Plug the power adapter cable into the device's mains connection.

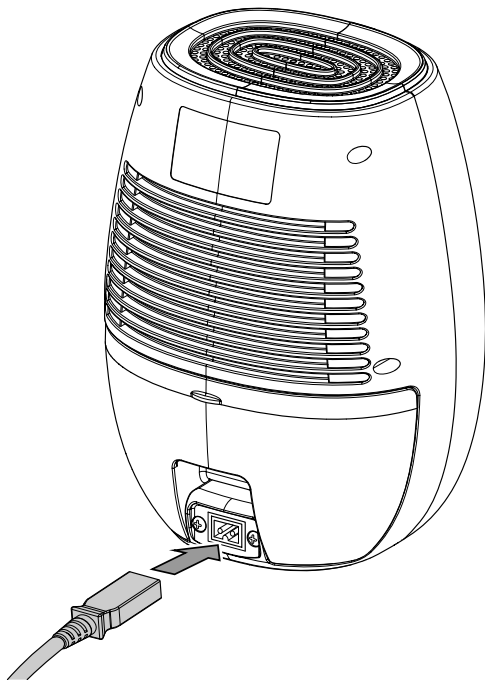

- Plug the power adapter into a properly fused mains socket.

Operation

- Avoid open doors and windows.
- After being switched on, the device operates fully automatically.

Operating elements

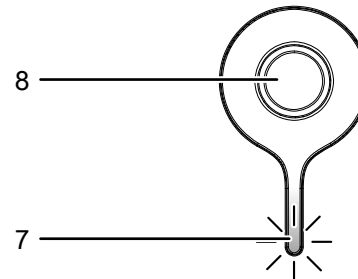

No.	Designation
7	Indicator LED: <ul style="list-style-type: none"> • is illuminated blue when the device is switched on and during operation • flashes blue if the power adapter is defective • is illuminated red when the water tank is full or the float is incorrectly positioned
8	On/off switch



Warning of electrical voltage

Risk of electric shock!

The device is not protected against water.

There is a risk of electric shock!

Never use the device in areas where dripping, spraying or running water can enter the device! Never immerse the device in water!

Switching the device on

Once you have completely installed the device as described in the chapter Assembly and start-up, you can switch it on.

1. Press the on/off switch (8).
 - ⇒ The LED at the on/off switch is illuminated in blue.
 - ⇒ The fan switches on.
 - ⇒ The device starts to dehumidify.

Shutdown



Warning of electrical voltage

Do not touch the mains plug with wet or damp hands.

- Switch the device off by pressing the on/off switch (8).
- Hold onto the mains plug while pulling the power cable out of the mains socket.
- Empty the condensation tank, if need be.
- Clean the device according to the Maintenance chapter.
- Store the device according to the Transport and storage chapter.

Errors and faults

The device has been checked for proper functioning several times during production. If malfunctions occur nonetheless, check the device according to the following list.

Notice

Wait for at least 3 minutes after maintenance and repair work. Only then switch the device back on.

The device does not start:

- Check the power connection.
- Check the power cable and mains plug for damage.
- Check the on-site fusing.
- Check the power adapter. The power adapter might be defective and needs to be replaced.
- Check the condensation tank for correct seating.
- Check whether the condensation tank is full. The indicator LED (7) is illuminated in red. Empty the condensation tank.
- The indicator LED (7) is illuminated in red. Check whether the float is incorrectly positioned or defective. Reposition the float (see chapter Assembly and start-up) or replace the float.
- The indicator LED (7) is illuminated in blue. The power cable with mains plug is defective. Do not use the device any more and order a new power cable with mains plug from Trotec.
- Check the room temperature. Observe the device's permissible ambient temperature according to the technical data.

The device is running, but there is no formation of condensate:

- Check the float in the condensation tank for dirt. If necessary, clean the condensation tank. The float must be able to move freely.
- Check the room temperature. Observe the device's permissible ambient temperature according to the technical data.
- Ensure that the relative room humidity complies with the technical data.

The device is loud or vibrates:

- Check whether the device is set up in a stable and upright position.

Condensate is leaking:

- Check the device for leaks.

The device gets very warm, is loud or is losing power:

- Check the air inlet for dirt. Remove external dirt.
- From the outside, check the device for dirt (see chapter Maintenance). If the inside of the device is dirty, have it cleaned by a specialist company or by Trotec.

The device still does not operate correctly after these checks:

Please contact the customer service. If necessary, bring the device to an authorised specialist electrical company or to the manufacturer for repair.

Maintenance

Maintenance intervals

Maintenance and care interval	before every start-up	as needed	at least every 2 weeks	at least every 4 weeks	at least every 6 months	at least annually
Check air inlet and outlet for dirt and foreign objects and clean if necessary	X			X		
Check air inlets and outlets for dirt and foreign objects and clean if necessary	X			X		
Clean the exterior		X				X
Visually check the inside of the device for dirt		X				X
Check for damage	X					
Test run						X
Empty and clean the condensation tank and/or drain hose		X				

Maintenance and care log

Device type:

Device number:

Maintenance and care interval	1	2	3	4	5	6	7	8	9	10	11	12	13	14	15	16
Check air inlets and outlets for dirt and foreign objects and clean if necessary																
Check air inlets and outlets for dirt and foreign objects and clean if necessary																
Clean the exterior																
Visually check the inside of the device for dirt																
Check for damage																
Test run																
Empty and clean the condensation tank and/or drain hose																
Comments																

1. Date: Signature:	2. Date: Signature:	3. Date: Signature:	4. Date: Signature:
5. Date: Signature:	6. Date: Signature:	7. Date: Signature:	8. Date: Signature:
9. Date: Signature:	10. Date: Signature:	11. Date: Signature:	12. Date: Signature:
13. Date: Signature:	14. Date: Signature:	15. Date: Signature:	16. Date: Signature:

Activities required before starting maintenance



Warning of electrical voltage

Do not touch the mains plug with wet or damp hands.

- Switch the device off.
- Hold onto the mains plug while pulling the power cable out of the mains socket.



Warning of electrical voltage

Tasks which require the device to be opened must only be carried out by authorised specialist companies or by the manufacturer.

Cleaning the housing

Clean the housing with a soft, damp and lint-free cloth. Make sure that no moisture enters the housing. Protect electrical components from moisture. Do not use any aggressive cleaning agents such as cleaning sprays, solvents, alcohol-based or abrasive cleaners to dampen the cloth.

Visual inspection of the inside of the device for dirt

1. Use a torch to illuminate the openings of the device.
2. Check the inside of the device for dirt.
3. If you see a thick layer of dust, have the inside of the device cleaned by a specialist company or by Trotec.

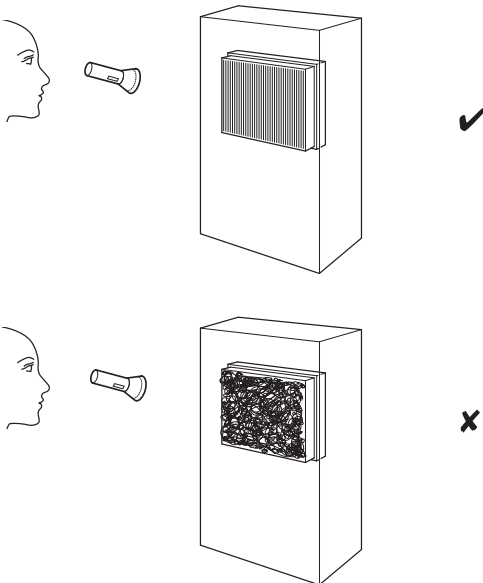

Emptying the condensation tank

If the condensation tank is full or the float is not correctly positioned, the indicator LED (7) lights up red and the device switches off.

1. Take the condensation tank (3) out of the device.

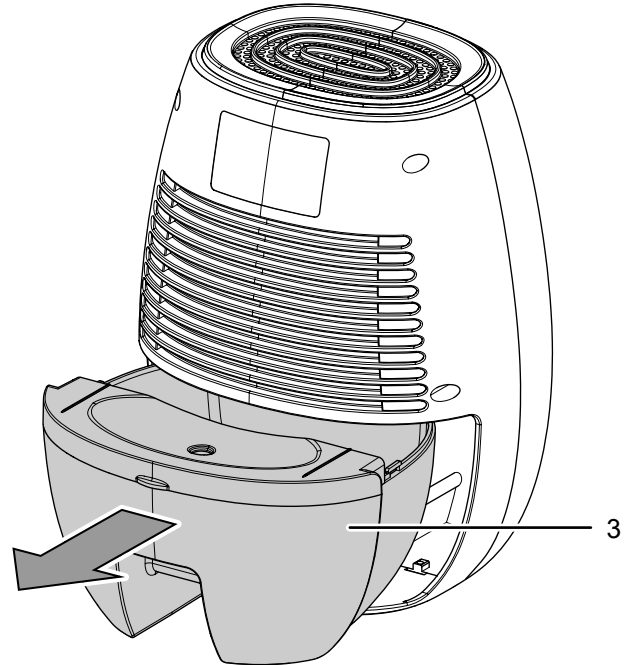

2. Empty the condensation tank (3) over a drain or sink.

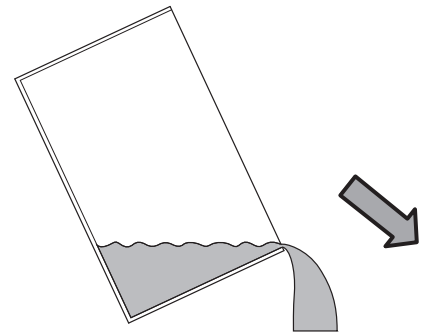

3. Rinse the tank with clear water. Clean the tank regularly using a mild cleaning agent (no detergent!).

4. Refit the condensation tank (3) into the device.
- ⇒ Make sure not to damage the float when inserting or removing the condensation tank.
 - ⇒ In doing so, make sure that the float is positioned correctly (see chapter Assembly and start-up).
 - ⇒ In doing so, make sure that the condensation tank is inserted correctly, for otherwise the device cannot be switched back on.

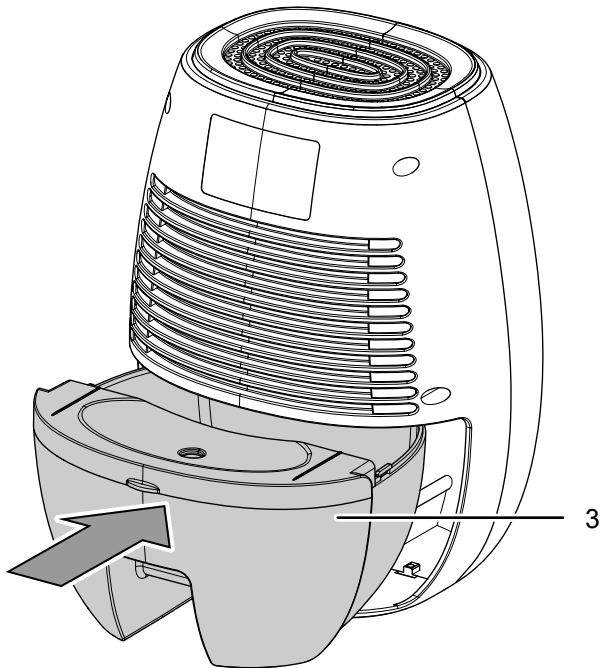

Activities required after maintenance

If you want to continue using the device:

- Reconnect the device to the mains.

If you do not intend to use the device for a considerable time:

- Store the device according to the Transport and storage chapter.

Technical annex

Technical data

Parameter	Value
Model	TTP 1 E / TTP 2 E
Max. dehumidification performance	220 ml / 24 h
Ambient temperature	16 °C to 35 °C
Mains connection	Power adapter
Input	100 V – 240 V / 50 – 60 Hz
Output	DC 9 V / 2.5 A
Power consumption	22 W
Nominal current	2.5 A
Type of protection	IPX0
Condensation tank capacity	500 ml
Sound pressure level (at a distance of 1 m)	35 dB(A)
Dimensions (depth x width x height)	95 x 150 x 220 mm
Minimum distance to walls and other objects	
	top (A): 10 cm
	rear (B): 10 cm
	sides (C): 10 cm
	front (D): 10 cm
Weight	1 kg

Disposal

Always dispose of packing materials in an environmentally friendly manner and in accordance with the applicable local disposal regulations.



The icon with the crossed-out waste bin on waste electrical or electronic equipment is taken from Directive 2012/19/EU. It states that this device must not be disposed of with the household waste at the end of its life. You will find collection points for free return of waste electrical and electronic equipment in your vicinity. The addresses can be obtained from your municipality or local administration. You can also find out about other return options that apply for many EU countries on the website <https://hub.trotec.com/?id=45090>. Otherwise, please contact an official recycling centre for electronic and electrical equipment authorised for your country.

The separate collection of waste electrical and electronic equipment aims to enable the re-use, recycling and other forms of recovery of waste equipment as well as to prevent negative effects for the environment and human health caused by the disposal of hazardous substances potentially contained in the equipment.

Only for United Kingdom

According to Waste Electrical and Electronic Equipment Regulations 2013 (SI 2013/3113) (as amended) devices that are no longer usable must be collected separately and disposed of in an environmentally friendly manner.

Trotec GmbH

Grebener Str. 7
D-52525 Heinsberg

☎ +49 2452 962-400

☎ +49 2452 962-200

✉ info@trotec.com

www.trotec.com