

WA 4i

EN

OPERATING MANUAL
WATER SEPARATOR



TABLE OF CONTENTS

01. General description	A - 01
02. Read before start-up	A - 01
03. Principle of operation	A - 03
04. Start-up	A - 04
05. Shutdown	A - 04
06. Care and maintenance	A - 05
07. Technical data WA 4 i	A - 06
08. Faults and troubleshooting	A - 06
09. Warranty	A - 07
10. EC Declaration of Conformity	A - 08

01. GENERAL DESCRIPTION

The water separator WA 4i is a device for commercial use that was designed for combined usage with the Trotec insulation dryers VX5, the HEPA filter and the NR silencers.

The insulation dryer and the water separator constitute an operating unit. The water separator WA 4i enables suction of both contaminated air containing water and free water itself.

02. READ BEFORE START-UP

- The WA 4i is to be used as a water separator for insulation drying of screeds or flat roofs. It must be set up vertically with all castors standing on flat ground. The device must not be used as storage place or footstep.
- For storage, up to 3 WA 4i devices may be stacked on top of one another. The WA 4i is positioned inside the provided borders.
- The WA 4i water separator's task is to keep water and dirt particles away from the intake flow of downstream side channel blower.



This release replaces all previous releases. No part of this publication may be reproduced without written permission. The same applies for electronically processing, duplicating or spreading the publication. Subject to technical changes. All rights reserved. Trademarks are used without guarantee that they may be used freely and primarily following the spelling of the manufacturer. The product names used are registered and should be treated appropriately. The right to make construction changes in the interests of constant product improvement as well as changes to the shape and colour is reserved. The scope of delivery may vary from product images. This document was produced with all due care. We accept no liability whatsoever for mistakes or omissions. © TROTEC®

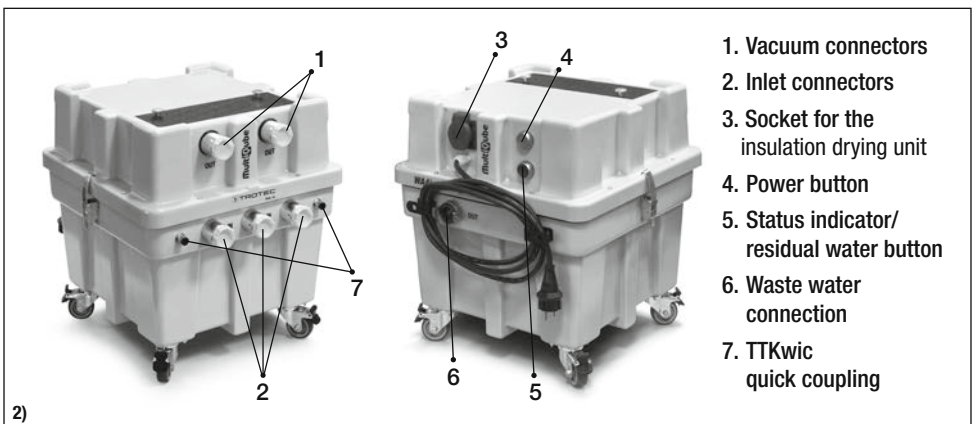

1. Vacuum connectors
2. Inlet connectors
3. Socket for the insulation drying unit
4. Power button
5. Status indicator/ residual water button
6. Waste water connection
7. TTKwic quick coupling

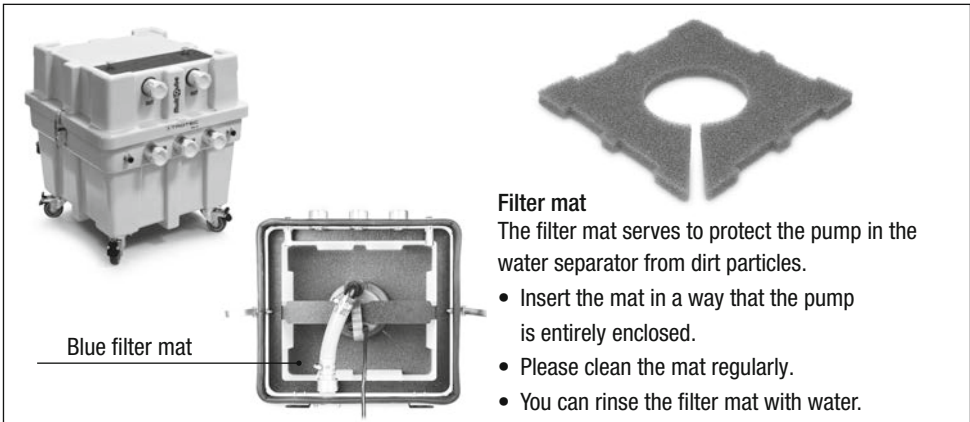

Filter mat

The filter mat serves to protect the pump in the water separator from dirt particles.

- Insert the mat in a way that the pump is entirely enclosed.
- Please clean the mat regularly.
- You can rinse the filter mat with water.

- The WA 4i is to be used in combination with a Trotec Insulation drying unit. The use of other insulation drying units may lead to an insufficient water separation and can thus cause damage.
- The WA 4i's function is the separation of solids and water during low-pressure insulation drying. To protect the insulation drying units, the WA 4i has fine filters with a filtration efficiency of 99 % at 2 µm installed (see fig. 4). If there is a risk posed by micro fibres or other harmful particles, the air exiting the WA 4i must be additionally cleaned with suitable filters.

- When using a downstream HEPA filter from Trotec, the particle filtration efficiency can be increased to 99.8 % of all particles up to a size of 0.3 µm.
- When using a Trotec silencer (see fig. 3), the noise level of the entire combined installation can be reduced by up to 17 dBA.
- Do not use the device with a relative humidity of more than 90 % or in the rain.
- **Please take the utmost care to ensure that neither water nor solids enter the downstream insulation drying unit.** This would lead to blocking of the turbine and thus to the destruction of the device. Therefore it is always necessary to install a suitable water separator upstream of the insulation drying unit in low-pressure operation (see fig. 3).
- To avoid harmful emissions, it is recommended to use HEPA filters in addition to the fine filters for every low-pressure application.
- The HEPA filters must be installed professionally between the water separator (OUT) and the insulation drying unit. The filters shown in the example (fig. 3) are consumables and must be exchanged and properly disposed of when they are dirty or saturated or after every application at the latest.

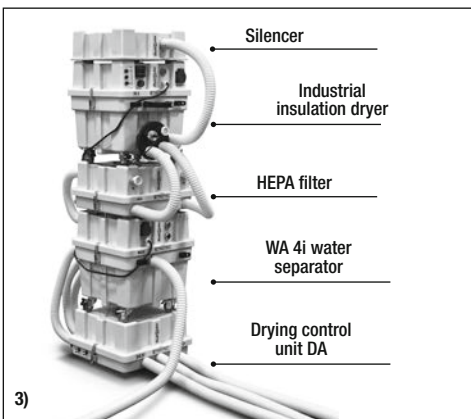

- When using a VE 4, VE 4 S or VX 5 insulation dryer, the 2 connection hoses are connected to the insulation drying unit via a T-piece, a Y-piece or a 4-way distributor.



Openings which are not used must be sealed with screw caps. The 4-way distributor ensures an aerodynamically optimised air flow and simplifies the assembly.

- For a proper use of fine filters and HEPA filters, observe the maximum air flow rate. Otherwise, an excessive air flow rate may cause damage to the filter insert and lead to the release of solids into the room air. Therefore sufficiently dimensioned filters must be installed which are suitable for the type of the insulation drying unit and vacuum air output. These filters must be inspected for damage and saturation and exchanged at suitable intervals depending on the concentration and risk of pollutants.
- If the use of a HEPA filter is necessary due to existing emissions, the air is only filtered when it leaves the water separator for process-related reasons. This means that contaminations occur in the separated water and on the inside of the device (e.g. also in the demister). Therefore, when discharging the separated water, make sure that only harmless water enters the drain. Contaminated water must be properly collected in a separate collection container and disposed of professionally.
- Using the WA 4i in potentially explosive rooms or atmospheres is prohibited.
- The WA 4i may only be operated by expert persons who have been instructed in the operation of the devices and trained in insulation drying techniques. The operating manual is to be consulted for this purpose. Instructed persons have been informed of and, if necessary, trained for the tasks they were entrusted with as well as of potential hazards resulting from inappropriate behaviour.

- Repair and maintenance work on electrical components may only be carried out by an electrically skilled person.
- On construction sites, the WA 4i water separators may only be connected via an electrical 1~230 V; 50 Hz; 16 A power supply with an upstream 30 mA residual current device (RCD) in accordance with DIN VDE 100.
- To avoid faults, the water separator must be checked for soiling, cleaned and, if necessary, disinfected at suitable intervals during or after each use depending on the degree of water contamination and the solid load.

When using extension cables/cable drums, always unroll the cable completely.

03. OPERATING PRINCIPLE

- The insulation drying unit is supplied with 1~ 230 V; 50 Hz via a series connection with the water separator WA 4i.
- The air sucked in by the insulation dryer is guided through hoses into the water separator. This is where rough solids and water are separated from the air.
- The "separated" air is filtered by the F8 fine filters, leaves the water separator and is released to the room air via the respective combination of the insulation drying unit. Water and solids remain in the water separator.
- By means of a float switch, the water separator monitors the tank's filling level and automatically pumps off the water using a centrifugal pump.
- If the water level in the tank rises faster than the pump can cope with, the insulation drying unit switches off automatically to avoid the risk of sucking in water. If the water level drops, the insulation dryer switches back on.
- The tank of the water separator is made of ABS thermoplastic. The inserted filter mat filters coarse dirt from the water and protects the pump and the check valve.

04. START-UP

- Position the water separator WA 4i horizontally. Make sure that the WA 4i cannot be knocked over. The 4 castors must point diagonally to the centre of the housing base and must be locked with the locking brakes on the outside. This increases the stability.
- The insulation drying unit can either be positioned next to or on top of the water separator WA 4i inside the provided borders. The 4 castors must point diagonally to the centre of the housing base and must be locked with the locking brakes on the outside. This increases the stability.
- Connect the vacuum connectors of the WA 4i to a suitable insulation dryer.
- Each insulation drying unit must be connected with 2 connection hoses $D = 38 \text{ mm}$.
- When discharging the separated water, make sure that only harmless water enters the drain. Connect the water drain hose to the tank via the GEKA coupling. If possible, guide the hose directly into a drain that is able to take the respective water quantities. Avoid differences in height larger than 2 m.
- Connect the suction hoses to the air inlet connectors (IN). 3 hoses maximum, $D = 38 \text{ mm}$. Only use the connectors in the tank wall. Do not use the vacuum connectors (OUT). Openings which are not used must be sealed with screw caps.
- Only use the forwarding socket for connecting the insulation drying unit.
- Connect the insulation dryer's connection cable to the respective socket on the WA 4i.
- Safety note: Trotec's water separator WA 4i is a system for continuous commercial use. If malfunctions occur, any interference with the system must be carried out by authorised expert staff only.
- If you are using a drying unit with pump for water damage restoration, you can directly connect the pump hose to the water separator tank. This way, you do not have to install individual hose lines on the construction site.



05. SHUTDOWN

- Switch off the insulation drying unit.
- By pressing the blue button (fig. 2 / item 5) after the end of the drying process, the tank can be drained almost completely.
- Never keep the pump running without water for more than 5 seconds (destruction due to dry running). For technical reasons, a residual amount of water always remains in the tank.
- Pull the mains plugs of the WA4i and of the insulation drying unit.

06. CARE AND MAINTENANCE

- After the work has been completed or in case of soiling, even during a drying process, the inside of the tank must be cleaned.

- After the work has been completed, the fine filters (fig. 4) must be exchanged. They are located in the maintenance-friendly filter compartment behind a magnetic lock cover. Open the black cover on top of the housing by pulling on both screw heads. Do not rotate the screw heads; only lift the cover. Unhook the cover on the opposite side. Then pull out the filter cartridge towards the top. Insert the new cartridge in the same direction. It cannot be fitted in a twisted way.

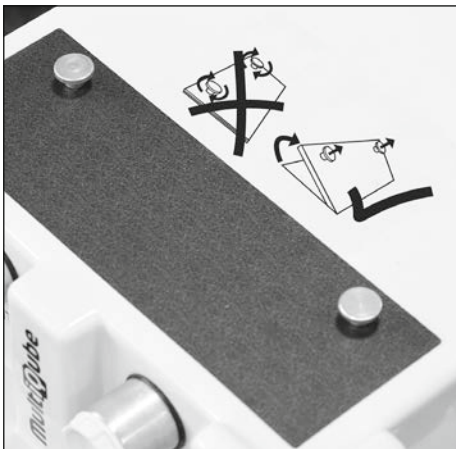
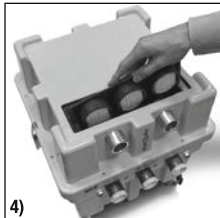

- Close the cover by hooking it in on one side first. Then push the screw heads down. The cover must be positioned evenly and flush with the housing.

- Take care of your health when carrying out cleaning work. Use gloves and, if necessary, a respiratory mask.

- Clean the blue filter mat. To do so, remove the mat from the tank and thoroughly rinse it with water. Afterwards re-insert the mat into the tank so that the lower part of the submerged pump is entirely enclosed.

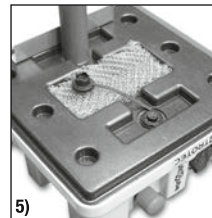

- Remove the mains plug from the socket to de-energize the device. Now remove all connections to the tank. Open the cover clamps, lift off the tank cover and disconnect the electrical connection between the pump and the cover by pulling the plugs. Put the tank cover safely aside.

- Carefully tip the tank over and remove any solids. Pay attention to damages to the pump and the two float switches. Check the pump's inlet openings. If necessary, clean them with water.

- If you disconnect the GEKA coupling and remove the pump latch, you can take out the submerged pump. This way, it can be freed even from stubborn dirt. During assembly, make sure that the pump is positioning correctly. Check the pump cable for damage.

- Always keep the WA 4i clean. Place the protective cap on the socket before cleaning the cover. Do not use pressurized water (high-pressure cleaner) to clean the tank cover.

- The cover of the WA 4i has an integrated stainless steel demister (wire mesh/fig. 5). It can be removed for cleaning. When re-inserting it, it should be flush with the edge of the cover.

- In case of contamination (see micro filter insert) with mould etc., the housing and the demister must be disinfected in addition to cleaning with water after every use. The disinfectant and cleaning method must be chosen depending on the type of soiling.
- Do not use any detergents containing solvents or abrasive detergents for cleaning. If necessary, test the effects of the detergent on a concealed spot of the ABS plastic housing.
- Due to internal material tension, white discolourations may occur on the devices of the MultiQube series. These crack-like stains do not have any influence on the functioning of the device and do not constitute a defect. The original state can be restored by exposing the device to hot air, e.g. using a hairdryer.
- Deformations of the housing caused by external influences (e.g. shocks or impacts) can in some cases be undone by performing suitable thermal treatment. Please contact the customer service.



The WA 4i has a powerful suction air flow. Small objects and particles can be sucked in and lead to injuries. Make sure that nobody is standing near the intake opening while the water separator is running and that all intake openings either have a hose connected to them or are closed with sealing plugs.

07. TECHNICAL DATA WA 4 I

Volume	17 l
Mains connection	1~ 230 V / 50 Hz
	CEE 7/7
Power input	0.32 kW
Nominal current	1.25 A
Fusing	16 A
Dimensions (L x W x H)	420 x 440 x 395 (mm)
Weight	11.3 kg
Air transport connection	3 x 38 mm
Micro filter cartridge	3 x F8 acc. to DIN EN 779
Quick coupling	2 x Ø 8 mm

08. FAULTS AND TROUBLESHOOTING

Little or no air is sucked in:

- Check the inlet openings, the demister, the blue filter mat and the fine filters (fig. 4) for dirt.
- Check whether the air inlet grid in the air ducts of the turbine (coarse particle protection) or the inlet openings of the separator are dirty or clogged.
- Check the air inlet grids in the air ducts of the insulation dryer for dirt.
- If HEPA filters are used, check the HEPA filters.

The pump does not drain:

- Check the electrical connections and fuses.
- Check the float switches for proper functioning.

09. WARRANTY

- The product's warranty period for material and manufacturing defects shall be 1 year from the date of delivery, provided the product is used in a normal and proper way and in accordance with this operating manual.
- There shall be no warranty claims for damage resulting from dirt.
- Devices under warranty are to be delivered in the original packaging.
- The warranty shall be voided if the design or technical construction of the device is modified by external interference.
- Only original spare parts may be used. In case of improper repair by third parties, all claims shall become void.



In the European Union, electronic equipment must not be treated as domestic waste, but must be disposed of professionally in accordance with Directive 2002/96/EC of the European Parliament and of the Council of 27 January 2003 on waste electrical and electronic equipment (WEEE). At the end of its life, please dispose of this device according to the relevant legal requirements.



Repair work should only be carried out by Trotec. When carried out by third parties, claims for liability and guarantee will be rendered null and void. Therefore, we recommend keeping the original packaging for the duration of the warranty period of this product. Transport costs shall not be borne by Trotec.

The machines are only intended for commercial use.

The machines may only be operated by expert persons who have been instructed in the operation of the devices and trained in insulation drying techniques. The operating manual is to be consulted for this purpose. Instructed persons have been informed of and, if necessary, trained for the tasks they were entrusted with as well as of potential hazards resulting from inappropriate behaviour.

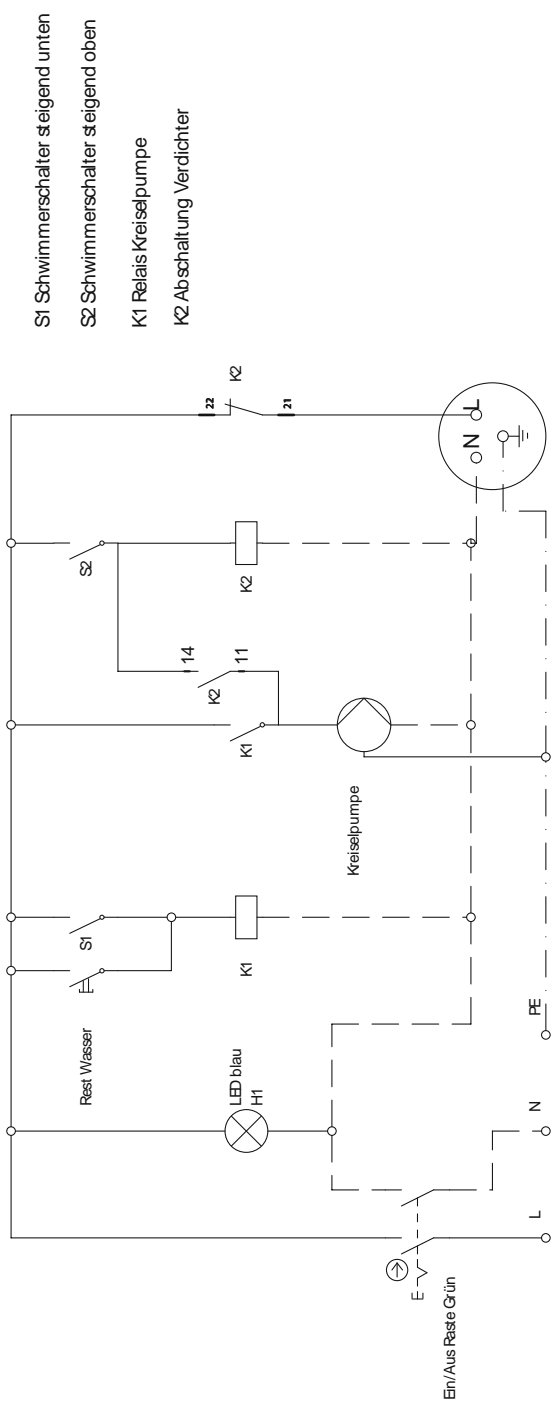

S1 Schwimmerschalter steigend unten
 S2 Schwimmerschalter steigend oben
 K1 Relais Keiselpumpe
 K2 Abschaltung Verdichter

Anschluß
 kabel

Werteplan sowie Verwirklichung dieser Vorzüge, Vervielfältigung und Verbreitung, auch auszugsweise, ist ohne schriftliche Genehmigung der Trotec GmbH & Co. KG. Zuwahlungen verpflichten zu Schadensersatz. Copying of this Document, and giving it to others and the use or communication of the payment of damages.



Trotec GmbH & Co. KG Grebbenerstr. 7 52525 Heinsberg 9

Dokumentart	Schaltplan
Estellt	EdeImann
Geprüft	
Genehmigt	
Titel	Wasserabscheider WA 4 Ser. XI
Rev.	b
Zeichnr.	800000000
Datum	19.06.2012
Lang.	de
Sheet	

EU Declaration of Conformity

In accordance with the EU Low Voltage Directive 2014/30/EU, Annex IV.

Trotec GmbH & Co. KG
Grebbener Straße 7
D-52525 Heinsberg

herewith declares that due to their design and construction, and in the version introduced by us, the following devices conform with the fundamental requirements of the EU directives listed below.

Important note:

In case of improper use, installation, maintenance etc. or unauthorized changes of the factory-supplied device version, this declaration loses its legal validity.

Device version:	Water separator	
Series:	WA 4i MultiQube	
Year of manufacture:	as of 2016	
Applicable regulations:	2014/30/EU	EMC Directive
	2014/35/EU	Low Voltage Directive
	2006/42/EC	Machinery Directive
	2012/19/EU	WEEE Directive
	2011/65/EU	RoHS
Applied harmonised standards:	VDE	0839-6-2: 2006: 03
	VDE	0839-6-3: 2011-09
		EN 60204-1: 2007
		EN 60335-1: 2012 + AC: 2014
		EN 60335-2-41: 2014-01
		EN 62233: 2008-11
	EMC	EN 55011: 2009 + A1:2010
		EN 61000-3-2: 2006 + A1: 2009 + A2: 2009
		EN 61000-3-3: 2008

Producer and authorised representative of the technical documentation:
Trotec GmbH & Co. KG · Grebbener Straße 7 · D-52525 Heinsberg
Phone: +49 2452 962-400 · Fax: +49 2452 962-200 · E-mail: info@trotec.com



Heinsberg, 20 April 2016

Managing Director: Detlef von der Lieck

Trotec GmbH & Co. KG

Grebbener Str. 7
D-52525 Heinsberg

☎ +49 2452 962-400

☎ +49 2452 962-200

✉ info@trotec.com

www.trotec.com